

UltraJoint™

Enclosed Metal Bellows Expansion Joint

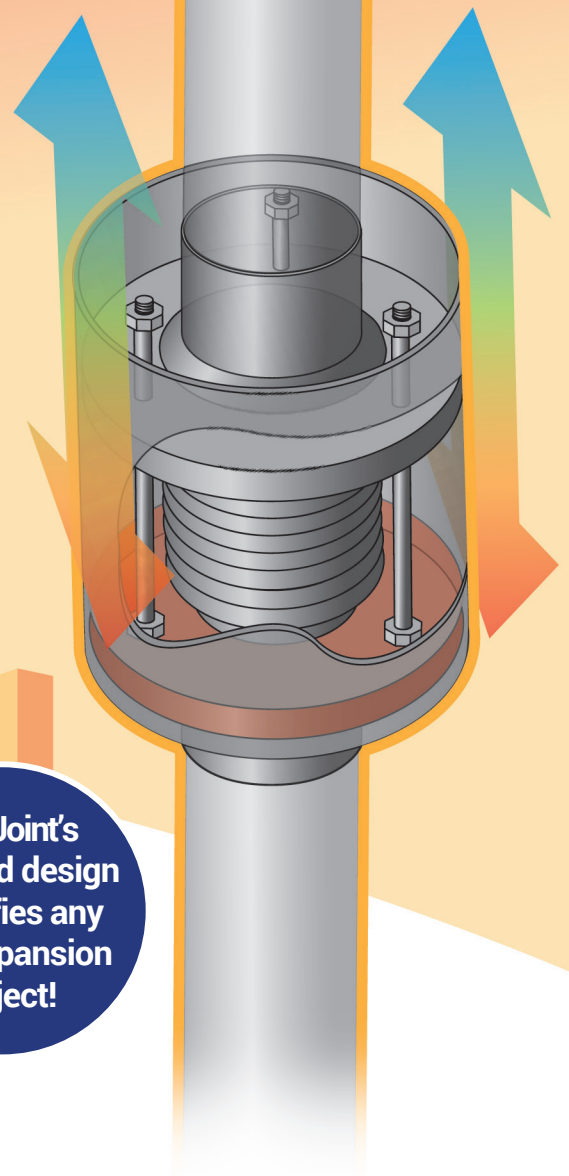

We built a better expansion joint for your building needs.

UltraJoint's patented design simplifies any pipe expansion project!

With UltraJoint™ you can eliminate the installation of two pipe guides for every metal bellows joint installed significantly reducing installation costs.

- **ECONOMICAL** – Eliminates guides for every UltraJoint
- **PROTECTS OVER-TRAVEL** – Built in travel limit assembly assures safety & performance
- **LARGE MOVEMENTS** – Absorbing axial pipe movements up to 3.25"
- **EASY TO INSULATE** – Simply wrap insulation over shroud
- **PIPE GUIDE SHROUD** – Encapsulated design protects from external impact & functions as a safety shield
- **HIGH WORKING PRESSURE** – Standard design working pressure to 300psi, test pressures 1.5xs
- **MULTIPLE FITTINGS AVAILABLE** – Grooved ends, welded ends and 150# and 300# flanges
- **Standard Sizes 2" to 24" I.D.**

PATENT # 8,033,576 B2

fh **FLEX-HOSE** CO. INC.

A world of difference in critical piping connections since 1968.™

CORPORATE HEADQUARTERS | DESIGN & MANUFACTURING

4560 Buckley Rd Liverpool NY 13088 | P: 315.437.1611 F: 315.437.1903



A World Of Difference That's Not a World Away

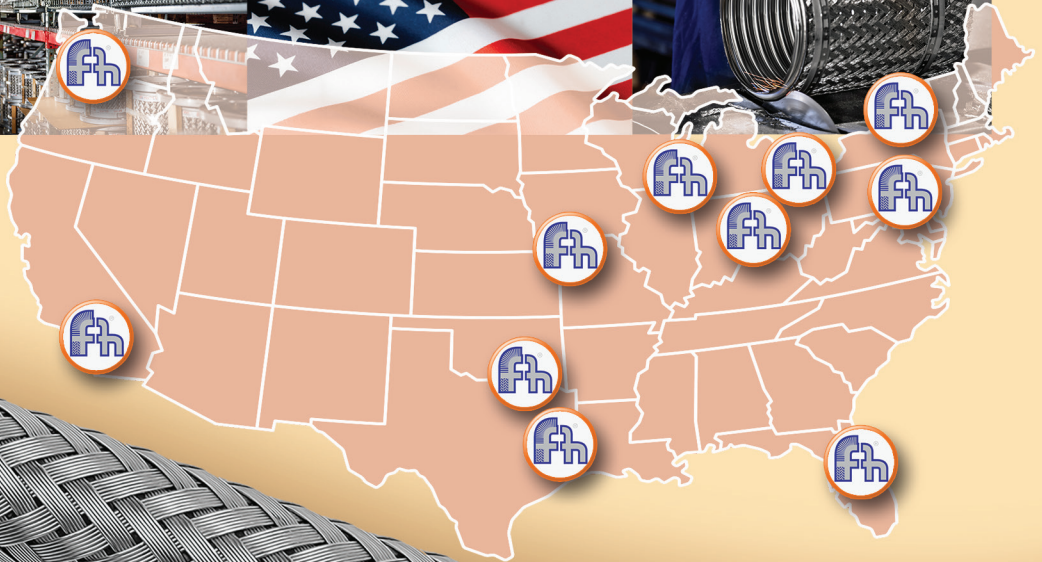

fh *FLEX-HOSE* CO. INC.

A world of difference in critical piping connections since 1968.™

CORPORATE HEADQUARTERS: 4560 Buckley Rd Liverpool NY 13088
P: 315.437.1611 | 1-877-TRI-FLEX | F: 315.437.1903 | www.flexhose.com

