



fh **FLEX-HOSE** CO. INC.



FULTRA **fuel flex** TM

Protecting Your Fuel Fired Equipment to meet the latest requirements of the International Building Code (IBC) and the American Society of Civil Engineers (ASCE)

 **CYCLE TESTED FOR**
20,000
cycles



Building Drift: Why Isolate Gas/Fuel Fired Equipment?

Flex-Hose Co. Inc's UL Listed UltraFuelFlex is a safe and reliable means to isolate piping systems between building structure and gas fired equipment to meet the displacement requirements set forth by the International Building Code (IBC) and the American Society of Civil Engineers (ASCE).

All current building codes for seismic and wind restraint design have the primary objectives: reduce the possibility of injury and threat to life, reduce long term cost due to equipment damage and resultant downtime.

FEMA (Federal Emergency Management Act) has identified one of the primary causes of property damage from earthquakes is the mechanical failure of gas and water lines contributing to fires.

The majority of U.S. jurisdictions have adopted the new international codes to insure financial backing from FEMA following an earthquake. All current building codes require seismic bracing of certain pipes. Damage occurs when pipes move independently of the building (see Figure 1). The ultimate goal of seismic bracing is to prevent damage to the pipe system by forcing it to move with the building. Other potential problems that occur are the incompatibility of piping systems with differential movement of the structure (drift) and bracing of piping with short/stiff service connections to equipment.

Fitting failures generally occur at or near equipment connections. The HVAC industry suggests the following should be considered when installing seismic restraints:

- Flexible connections should be provided between equipment that is braced and piping that need not be braced.
- Flexible connections should be provided between isolated equipment and braced piping.

The International Building Code (IBC) and the American Society of Civil Engineers (ASCE), realize the importance of protecting piping systems conveying flammable and combustible gases. Flex-Hose Co., Inc.'s UltraFuelFlex UL536 Listed connectors are approved for flammable and combustible gases. They are the ultimate protection for isolating critical gas/fuel fired equipment.

Standard Sizes 1" to 4" I.D.

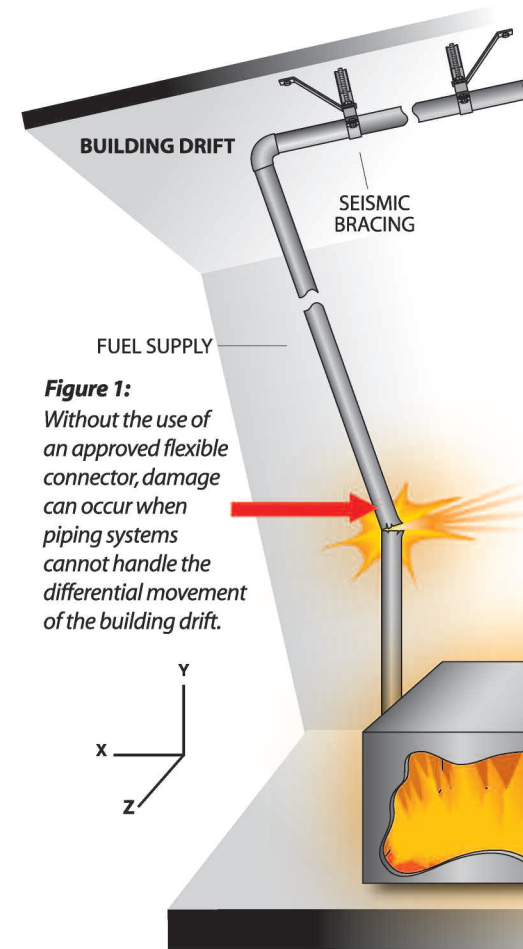
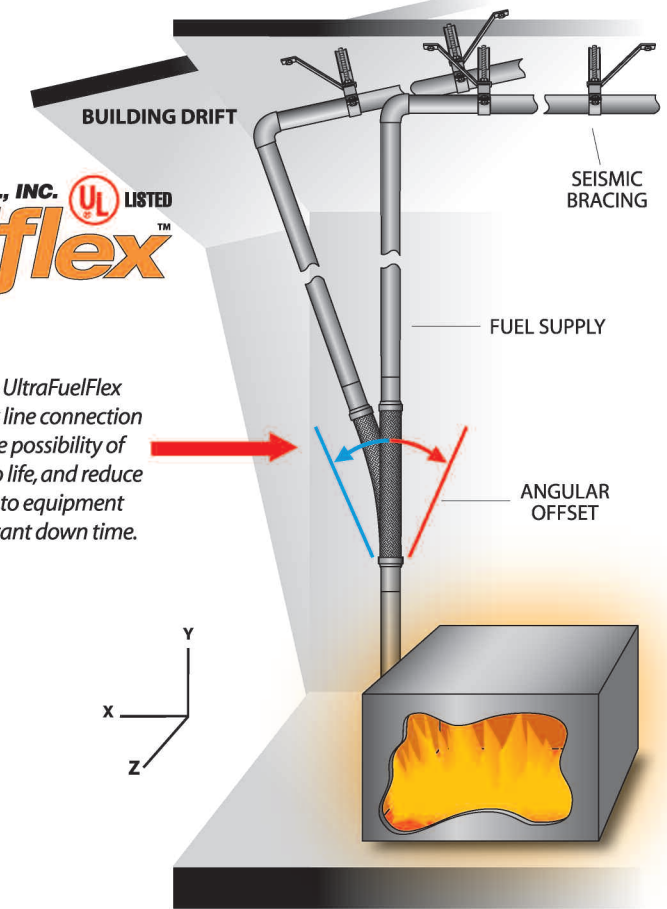
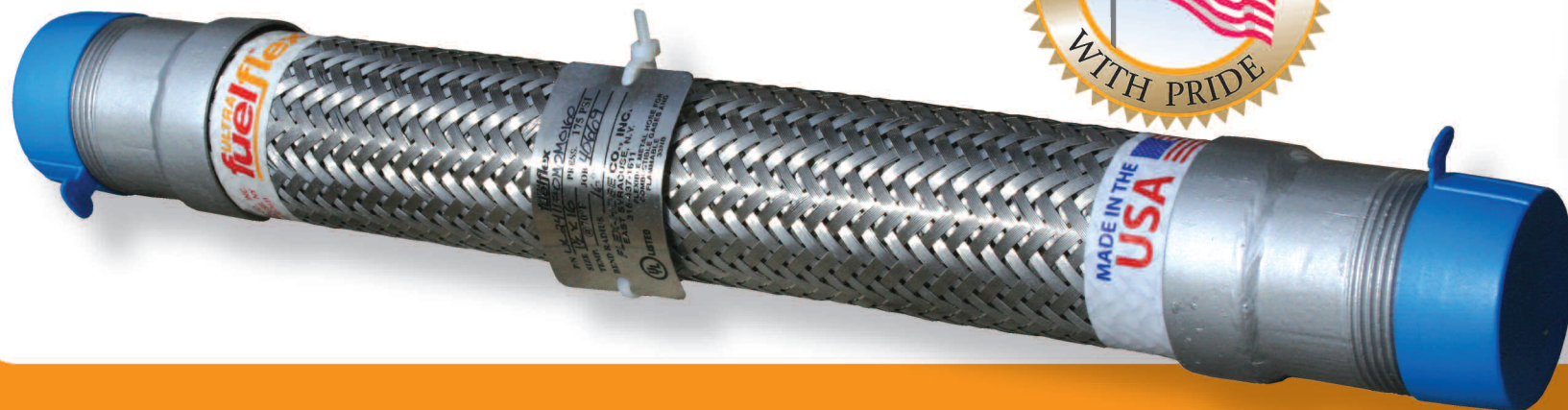

Figure 1: Without the use of an approved flexible connector, damage can occur when piping systems cannot handle the differential movement of the building drift.



FLEX-HOSE CO., INC. UL LISTED
FULTRA fuelflex™

Figure 2: Flex-Hose Co., Inc.'s UltraFuelFlex prevent fuel supply line connection failure, reducing the possibility of injury and threat to life, and reduce long term cost due to equipment damage and resultant downtime.



FULTRA fuelflex™

Protecting Your Fuel Fired Equipment

www.flexhose.com

ASME Section IX



FULTRA fuel flex™

Passing the Test

Quality Assurance

Safety and performance has always been the heart and soul of the UltraFuel Flex product's design. They have been tested, listed, labeled, and regularly inspected by Underwriters Laboratory to ensure they meet or exceed industry performance standards.

UltraFuel Flex is manufactured with 321 (ASTM A240) grade stainless steel metal flexible hose, making it an extraordinarily flexible connection. One of the rigorous testing requirements of UL536 testing is flexure cycle testing. UltraFuel Flex was flexure tested for 20,000 cycles while maintaining a working pressure of 175 psig. Upon successful completion of 20,000 cycles, UltraFuel Flex was pressurized to 875 psig (5:1 safety factor) and maintained pressure integrity... Passing the test!

Applications

Flex-Hose Co. UltraFuel Flex UL536 Listed connectors are approved for flammable and combustible gases. They are used to prevent damage to critical gas/fuel fired equipment caused by piping stress where rigidly supported pipes connect to equipment. UltraFuel Flex are easily installed and reduce the possibility of equipment connection failure. Common applications include gas connections on boilers, water heaters, and unit heaters and fuel connections on emergency generators and gas turbine engine installations.

Pressures

UltraFuel Flex are designed for a maximum working pressure of 175 psi at 70°F and are capable of system test to 262 psig. Manufactured with 5:1 safety factor.

All UltraFuel Flex are 100% hydrostatic tested at the factory to 262 psig to insure trouble free installation and years of quality service.

UL536 Requirements

UltraFuel Flex connectors have a UL536 listing having a nominal inside diameter from 1 to 4 inches intended for use in piping systems carrying flammable and combustible gases at pressures not exceeding 175 psi at ambient temperature.

Note: The term flammable and combustible gases, as used herein, means gases such as liquefied petroleum gases, and manufactured and natural fuel gases.

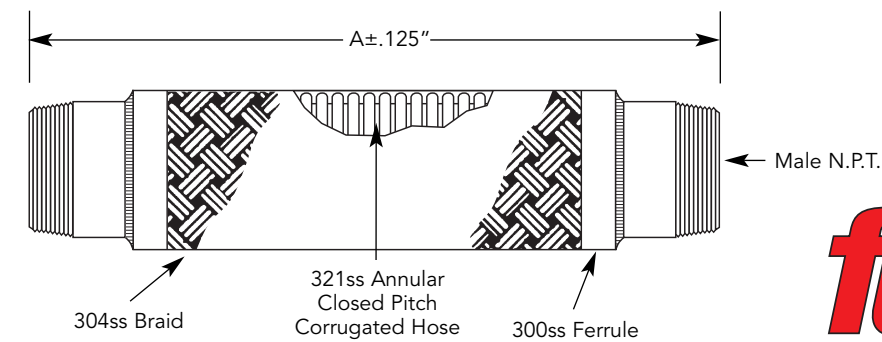

UFFMN-UL 1"-4" I.D. (Threaded Ends)

I.D. (In.)	A (In.)	Pressure (PSI) 70°F	Parallel Offset (In.)		Angular Deflection (Deg.)	Weight (Lb.)
			Permanent	Intermittent		
1.00	16.00	175	1.75	1.12	80°	1.40
1.25	16.00	175	1.75	1.00	50°	1.78
1.50	16.00	175	1.75	.75	50°	2.20
2.00	21.00	175	2.75	1.12	60°	3.76
2.50	22.00	175	2.50	.75	60°	5.60
3.00	22.00	175	1.75	.62	50°	7.68
4.00	25.00	175	2.00	.75	40°	10.70

*Working pressures shown for hose and braid are based on an operating temperature of 70°F (21°C) with a 5:1 safety factor.

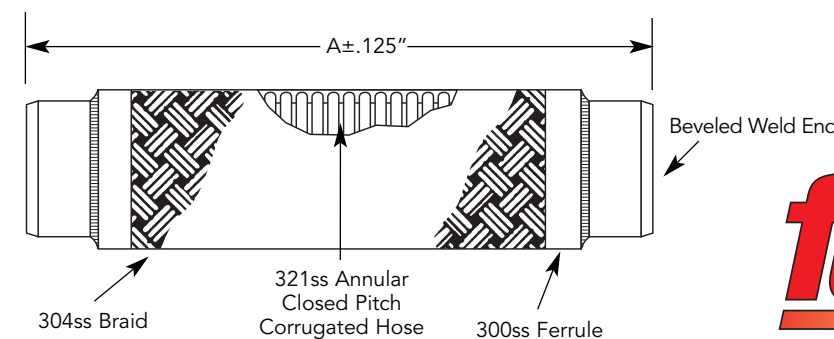

UFFWN-UL 1"-4" I.D. (Weld Ends)

I.D. (In.)	A (In.)	Pressure (PSI) 70°F	Parallel Offset (In.)		Angular Deflection (Deg.)	Weight (Lb.)
			Permanent	Intermittent		
1.00	18.00	175	1.75	1.12	80°	1.68
1.25	18.00	175	1.75	1.00	50°	2.16
1.50	19.00	175	1.75	.75	50°	2.89
2.00	22.00	175	2.75	1.12	60°	4.07
2.50	23.00	175	2.50	.75	60°	6.08
3.00	24.00	175	1.75	.62	50°	8.94
4.00	27.00	175	2.00	.75	40°	13.50

*Working pressures shown for hose and braid are based on an operating temperature of 70°F (21°C) with a 5:1 safety factor.

NOTE: Assembly lengths are the minimum required to achieve movements noted on charts. Movements can increase by adding to the overall length. Please consult factory. Manufactured with 5:1 safety factor.

FULTRA fuel flex™

CYCLE TESTED FOR 20,000 cycles

One of the rigorous testing requirements of UL536 testing is flexure cycle testing. UltraFuel Flex was flexure tested for 20,000 cycles while maintaining a working pressure of 175 psig. Upon successful completion of 20,000 cycles, UltraFuel Flex was pressurized to 875 psig (5:1 safety factor) and maintained pressure integrity.

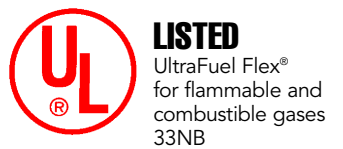

Note: The term flammable and combustible gases, as used herein, means gases such as liquefied petroleum gases, and manufactured and natural fuel gases.

FULTRA fuel flex™

CYCLE TESTED FOR 20,000 cycles

One of the rigorous testing requirements of UL536 testing is flexure cycle testing. UltraFuel Flex was flexure tested for 20,000 cycles while maintaining a working pressure of 175 psig. Upon successful completion of 20,000 cycles, UltraFuel Flex was pressurized to 875 psig (5:1 safety factor) and maintained pressure integrity.



Note: The term flammable and combustible gases, as used herein, means gases such as liquefied petroleum gases, and manufactured and natural fuel gases.

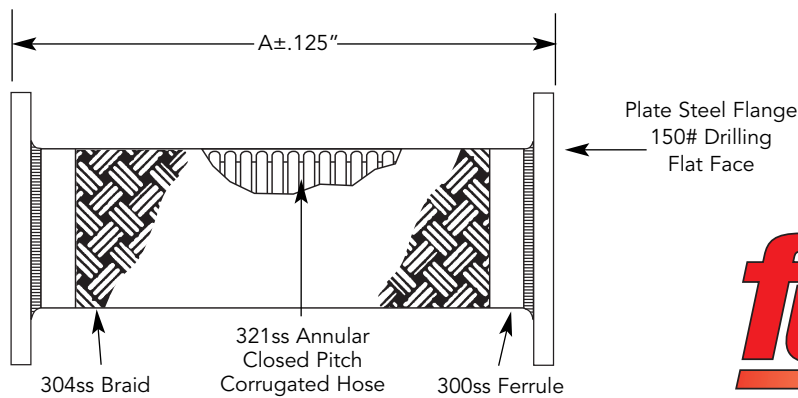

CYCLE TESTED FOR 20,000 cycles

One of the rigorous testing requirements of UL536 testing is flexure cycle testing. UltraFuel Flex was flexure tested for 20,000 cycles while maintaining a working pressure of 175 psig. Upon successful completion of 20,000 cycles, UltraFuel Flex was pressurized to 875 psig (5:1 safety factor) and maintained pressure integrity.



Note: The term flammable and combustible gases, as used herein, means gases such as liquefied petroleum gases, and manufactured and natural fuel gases.

UFFMP-UL 1"-4" I.D. (Flanged Ends)

I.D. (In.)	A (In.)	Pressure (PSI) 70°F	Parallel Offset (In.)		Angular Deflection (Deg.)	Weight (Lb.)
			Permanent	Intermittent		
1.00	14.00	175	1.75	1.12	80°	5.00
1.25	14.00	175	1.75	1.00	50°	6.00
1.50	14.00	175	1.75	.75	50°	7.00
2.00	17.00	175	2.75	1.12	60°	11.00
2.50	17.00	175	2.50	.75	60°	14.00
3.00	17.00	175	1.75	.62	50°	16.00
4.00	20.00	175	2.00	.75	40°	23.00

*Working pressures shown for hose and braid are based on an operating temperature of 70°F (21°C) with a 5:1 safety factor.

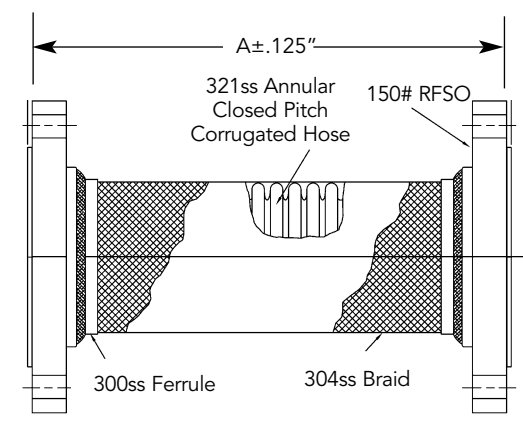

CYCLE TESTED FOR 20,000 cycles

One of the rigorous testing requirements of UL536 testing is flexure cycle testing. UltraFuel Flex was flexure tested for 20,000 cycles while maintaining a working pressure of 175 psig. Upon successful completion of 20,000 cycles, UltraFuel Flex was pressurized to 875 psig (5:1 safety factor) and maintained pressure integrity.

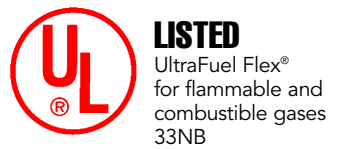

Note: The term flammable and combustible gases, as used herein, means gases such as liquefied petroleum gases, and manufactured and natural fuel gases.

UFFRR-UL 1"-4" I.D. (Flanged Ends)

I.D. (In.)	A (In.)	Pressure (PSI) 70°F	Parallel Offset (In.)		Angular Deflection (Deg.)	Weight (Lb.)
			Permanent	Intermittent		
1.00	15.00	175	1.75	1.12	80°	6.00
1.25	15.00	175	1.75	1.00	50°	8.00
1.50	15.00	175	1.75	.75	50°	9.00
2.00	18.00	175	2.75	1.12	60°	14.00
2.50	19.00	175	2.50	.75	60°	20.00
3.00	19.00	175	1.75	.62	50°	23.00
4.00	22.00	175	2.00	.75	40°	32.00

*Working pressures shown for hose and braid are based on an operating temperature of 70°F (21°C) with a 5:1 safety factor.

NOTE: Assembly lengths are the minimum required to achieve movements noted on charts. Movements can increase by adding to the overall length. Please consult factory. Manufactured with 5:1 safety factor.

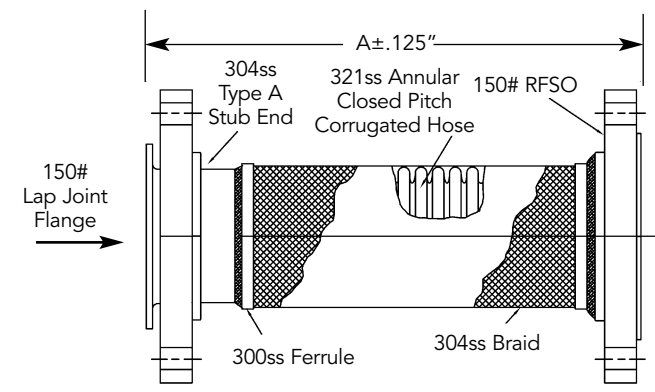

CYCLE TESTED FOR 20,000 cycles

One of the rigorous testing requirements of UL536 testing is flexure cycle testing. UltraFuel Flex was flexure tested for 20,000 cycles while maintaining a working pressure of 175 psig. Upon successful completion of 20,000 cycles, UltraFuel Flex was pressurized to 875 psig (5:1 safety factor) and maintained pressure integrity.



Note: The term flammable and combustible gases, as used herein, means gases such as liquefied petroleum gases, and manufactured and natural fuel gases.

UFFRY-UL 1"-4" I.D. (Flanged Ends)

I.D. (In.)	A (In.)	Pressure (PSI) 70°F	Parallel Offset (In.)		Angular Deflection (Deg.)	Weight (Lb.)
			Permanent	Intermittent		
1.00	16.00	175	1.75	1.12	80°	7.00
1.25	16.00	175	1.75	1.00	50°	9.00
1.50	16.00	175	1.75	.75	50°	10.00
2.00	20.00	175	2.75	1.12	60°	15.00
2.50	20.00	175	2.50	.75	60°	21.00
3.00	20.00	175	1.75	.62	50°	26.00
4.00	24.00	175	2.00	.75	40°	35.00

*Working pressures shown for hose and braid are based on an operating temperature of 70°F (21°C) with a 5:1 safety factor.

NOTE: Assembly lengths are the minimum required to achieve movements noted on charts. Movements can increase by adding to the overall length. Please consult factory. Manufactured with 5:1 safety factor.

Motion Classifications

Flex-Hose Co.'s UltraFuel Flex UL536 listed connectors are capable of handling the following movements:

Parallel Offset:

Motion that occurs when one end of the hose assembly is deflected in a plane perpendicular to the longitudinal axis with the ends remaining parallel. Offset is measured as displacement of the free end centerline from the fixed end centerline.

Angular Offset:

Angular movement is defined as the bending of the hose so that the ends are no longer parallel. Amount of movement is measured in degrees from centerline of the hose if were installed straight.

Motion Frequency:

Permanent Offset - The maximum fixed parallel offset to which the UltraFuel Flex assembly may be bent without damage to the convolutions. No further motion is to be imposed other than normal vibration.

Intermittent Offset is motion that occurs on a regular or irregular cyclic basis. It is normally the result of seismic motion, or other non-continuous actions such as thermal expansion and contraction.

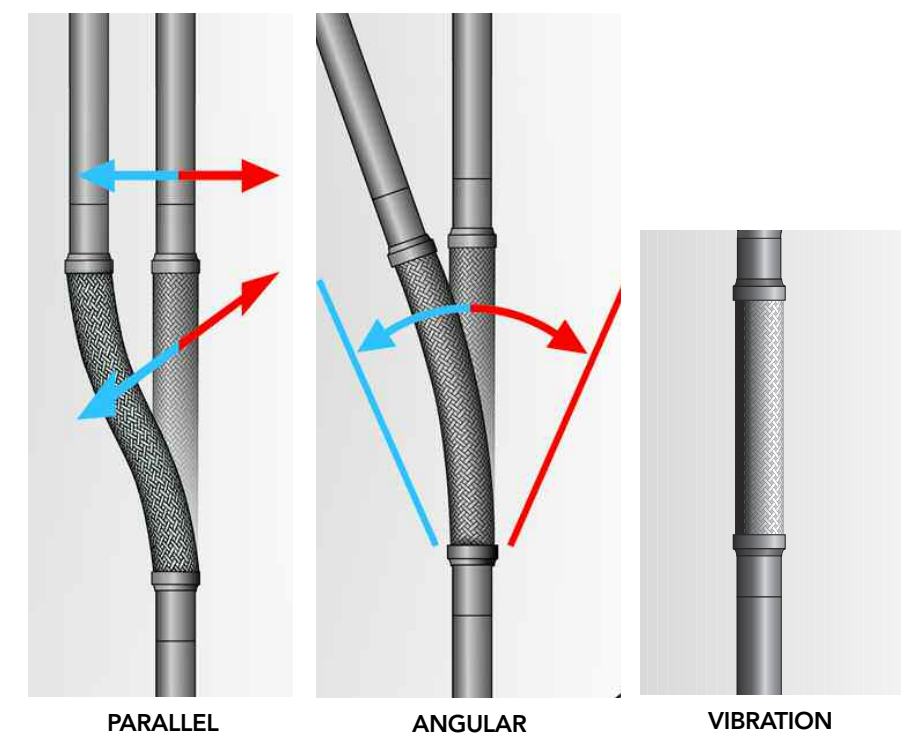

PARALLEL

ANGULAR

VIBRATION

Visit our website for more information on our broad range of products.

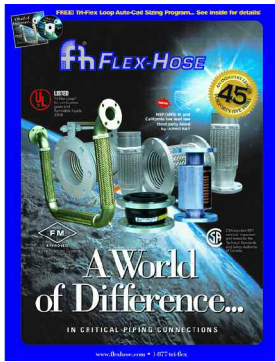

Product Overview

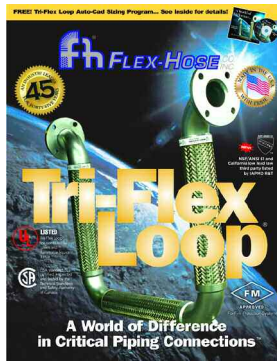

Flexible Pipe Loop

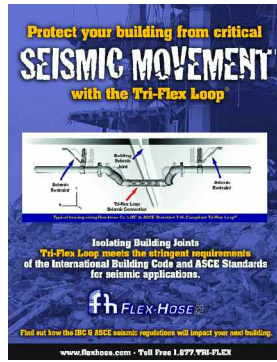

IBC Compliant Seismic Connections

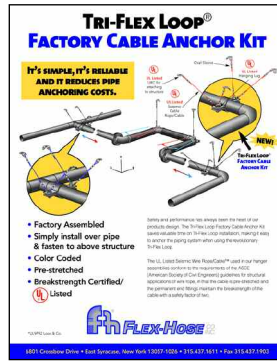

Flexible Pipe Loop Hanger Kit & Accessories

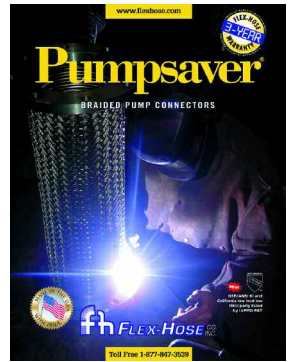

Braided Metal Pump Connectors



Expansion Joint Application Guide

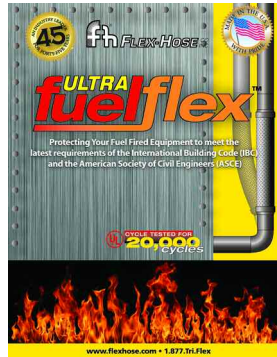

Flexible Gas Connection

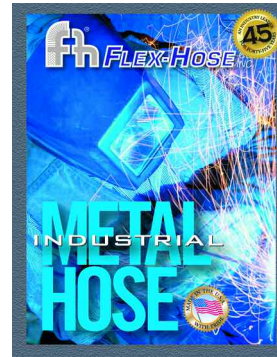

Industrial Metal Hose

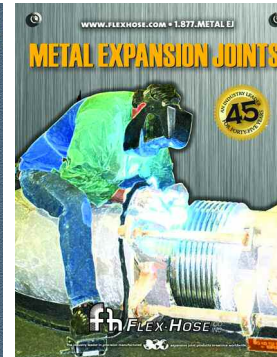

Metal Bellows Expansion Joints



Enclosed Metal Bellows Expansion Joints

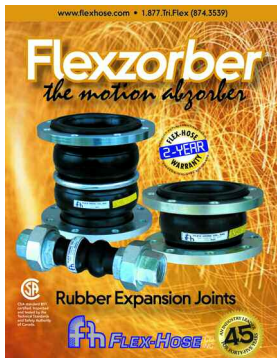

Rubber Expansion Joints



Expansion Joint Control Assemblies

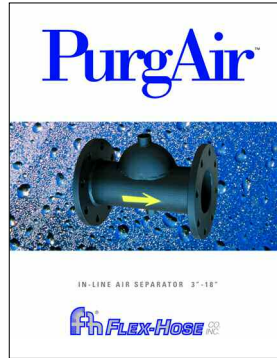

Air Separators



Expansion Compensators

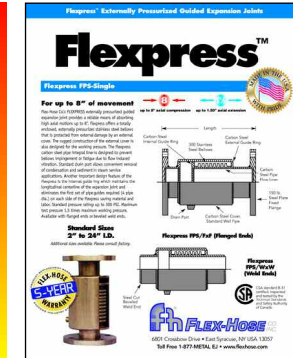

Externally Pressurized Expansion Joints

A World of Difference in Critical Piping Connections since 1968.



Corporate Headquarters

6801 Crossbow Drive • East Syracuse, NY 13057
315.437.1611 • Fax 315.437.1903

Expanded Design and Manufacturing Operation

6809 Crossbow Drive • East Syracuse, NY 13057
315.701.0001 • Fax 315.701.0032

Toll Free 1-877-Tri-Flex (874-3539) • Email: sales@flexhose.com