

# FULTRA *fuelflex*™

## UL Listed Connectors for Gas/Fuel Fired Equipment

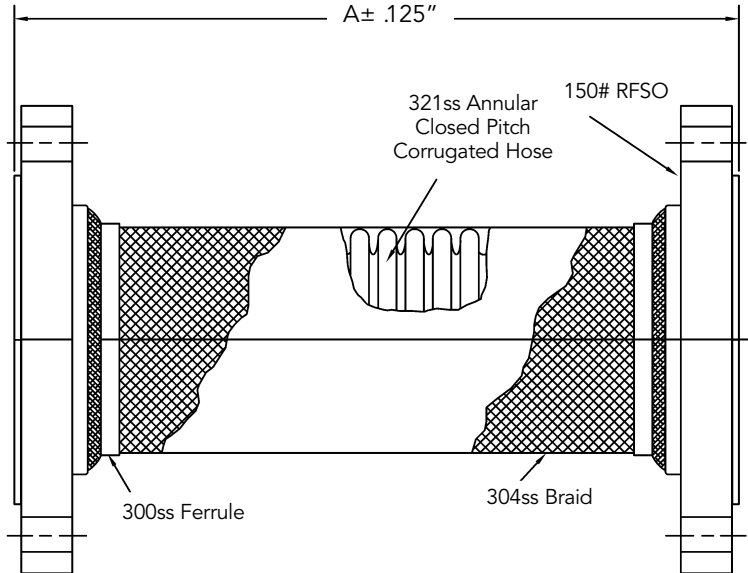

**LISTED**  
UltraFuel Flex®  
for compressed and  
combustible gases  
33NB

Note: The term compressed and combustible gases, as used herein, means gases such as liquefied petroleum gases, and manufactured and natural fuel gases.

Qty	I.D. (In.)	A (In.)	Pressure (PSI) 70°F	Parallel Offset (In.)		Angular Deflection (Deg.)	Weight (Lb.)
				Permanent	Intermittent		
1.00	1.00	15.00	175	1.75	1.12	80°	6.00
1.25	1.25	15.00	175	1.75	1.00	50°	8.00
1.50	1.50	15.00	175	1.75	.75	50°	9.00
2.00	2.00	18.00	175	2.75	1.12	60°	14.00
2.50	2.50	19.00	175	2.50	.75	60°	20.00
3.00	3.00	19.00	175	1.75	.62	50°	23.00
4.00	4.00	22.00	175	2.00	.75	40°	32.00

\*Working pressures shown for the hose and braid are based on an operating temperature of 70°F (21°C) with a 5:1 safety factor.

NOTE: Assembly lengths are the minimum required to achieve movements noted on charts. Movements can increase by adding to the overall length. Please consult factory.

**CYCLE TESTED FOR**  
**20,000**  
**cycles**

One of the rigorous testing requirements of UL536 testing is flexure cycle testing. UltraFuel Flex was flexure tested for 20,000 cycles while maintaining a working pressure of 175 psig. Upon successful completion of 20,000 cycles, UltraFuel Flex was pressurized to 875 psig (5:1 safety factor) and maintained pressure integrity.

### END FITTING MATERIAL SPECIFICATIONS

CARBON STEEL

STAINLESS STEEL

PROJECT	
CUSTOMER	
ENGINEER	
REPRESENTATIVE	
DRAWING #	



4560 Buckley Road  
Liverpool, NY USA 13088-2509  
315/437-1611 • Fax 315/437-1903  
www.flexhose.com • 1.877.TRI FLEX

UL LISTED CONNECTORS

UFFRR-UL 1"-4" I.D.