

Pumpsaver® Braided Pump Connectors

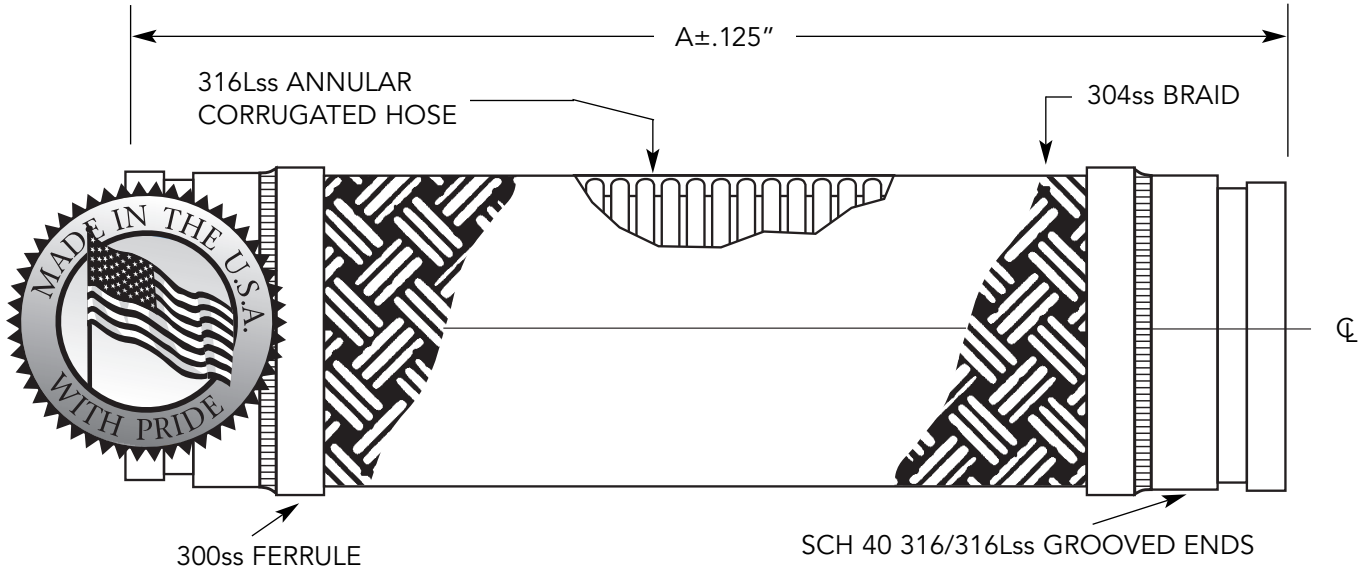

| FOR TEMP ABOVE 70°F | |
|---------------------|-----------------|
| TEMP °F | FACTOR 316 S.S. |
| 70 | 1.00 |
| 200 | .92 |
| 300 | .86 |
| 400 | .82 |
| 500 | .77 |
| 600 | .73 |

| Qty. | I.D (in.) | A (in.) | Pressure (PSI) 70° F | Parallel Offset (in.) | | Weight (lbs.) | Notes |
|------|-----------|---------|----------------------|-----------------------|--------------|---------------|-------|
| | | | | Permanent | Intermittent | | |
| | 2.00 | 12.00 | 500 | 1 1/4 | 3/8 | 3.90 | |
| | 2.50 | 12.00 | 400 | 1 1/4 | 3/8 | 4.50 | |
| | 3.00 | 12.00 | 285 | 3/4 | 1/4 | 6.10 | |
| | 4.00 | 14.00 | 250 | 1/2 | 1/4 | 9.30 | |
| | 5.00 | 16.00 | 200 | 7/8 | 3/8 | 11.80 | |
| | 6.00 | 16.00 | 220 | 5/8 | 1/4 | 16.80 | |
| | 8.00 | 16.00 | 200 | 1/2 | 1/4 | 23.50 | |
| | 10.00 | 20.00 | 200 | 5/8 | 1/4 | 44.10 | |
| | 12.00 | 20.00 | 160 | 1/2 | 1/4 | 51.50 | |

*Working pressures shown for the hose and braid are based on an operating temperature of 70°F (21°C) with a 4:1 safety factor.

*For safe working pressure above 70°F, multiply pressure shown at 70°F times correction factor of required temp.



This product is listed by IAPMO R&T under file #N-7208 for NSF/ANSI 61 and file 7207 for California Lead Plumbing Law and NSF/ANSI-372. Our listed products can be viewed on IAPMO R&T's Web listing at <http://pld.iapmo.org>



CSA standard B-51 certified. Inspected and tested by the Technical Standards and Safety Authority of Canada.



4560 Buckley Road
 Liverpool, NY USA 13088-2509
 315/437-1611 • Fax 315/437-1903
www.flexhose.com • 1.877.METAL EJ

| | |
|----------------|--|
| PROJECT | |
| CUSTOMER | |
| ENGINEER | |
| REPRESENTATIVE | |
| DRAWING # | |