

QuikPress® Braided Hose Assemblies

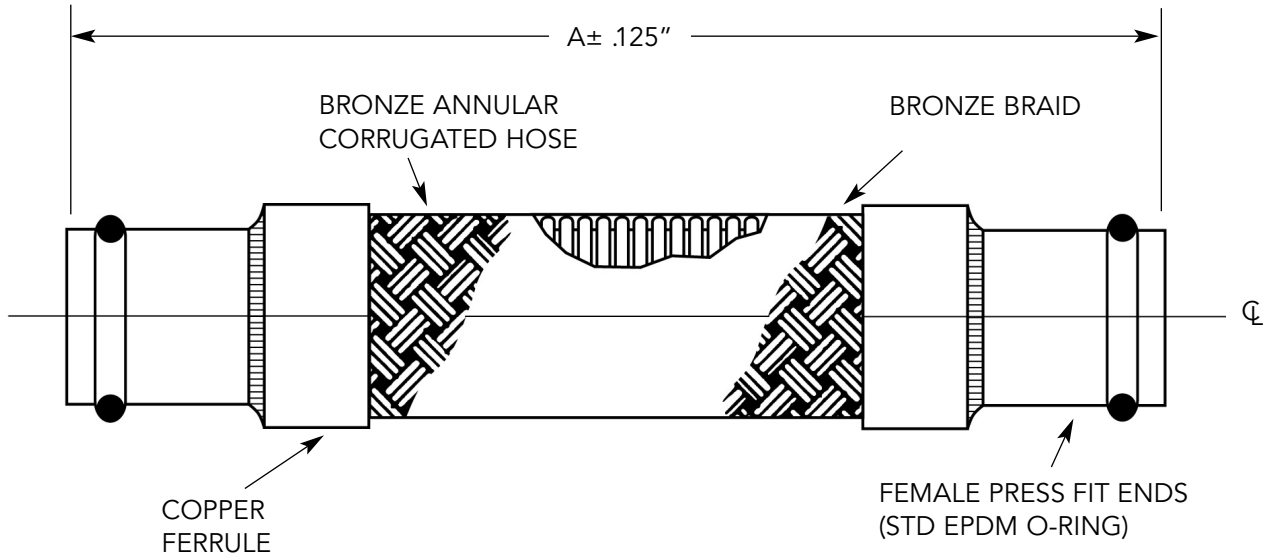

QTY	I.D. (In.)	A (In.)	Pressure (PSI) 250°F	Parallel Offset One Side of Centerline (In.)	Weight (lb)
	.50	18.0	200	3.875	1.15
	.75	18.0	200	3.125	1.85
	1.00	18.0	200	2.75	2.10
	1.25	18.0	200	2.125	2.90
	1.50	18.0	200	1.50	4.05
	2.00	18.0	180	1.125	5.20

**Working pressures based on maximum fitting capability at 250°F.
Fitting manufacturer suggested 15-85PSI water pressure test to confirm all fittings are pressed. System can then be tested to a maximum water pressure of 200PSI @ 70°F.*



NSF/ANSI 61
IAPMO R&T

This product is listed by IAPMO R&T under file #N-7208 for NSF/ANSI 61 and file 7207 for California Lead Plumbing Law and NSF/ANSI-372. Our listed products can be viewed on IAPMO R&T's Web listing at <http://pld.iapmo.org>. This BSW copper product has been evaluated for use in drinking water systems pH 6.5 and above. Drinking water supplies that are less than pH 6.5 may require corrosion control to limit leaching of copper into the drinking water.



CSA standard B-51 certified.
Inspected and tested by the
Technical Standards and
Safety Authority of Canada.



PROJECT	
CUSTOMER	
ENGINEER	
REPRESENTATIVE	
DRAWING #	



4560 Buckley Road
Liverpool, NY USA 13088-2509
315/437-1611 • Fax 315/437-1903
www.flexhose.com • 1.877.TRI FLEX