

WWW.FLEXHOSE.COM

PurgAir™

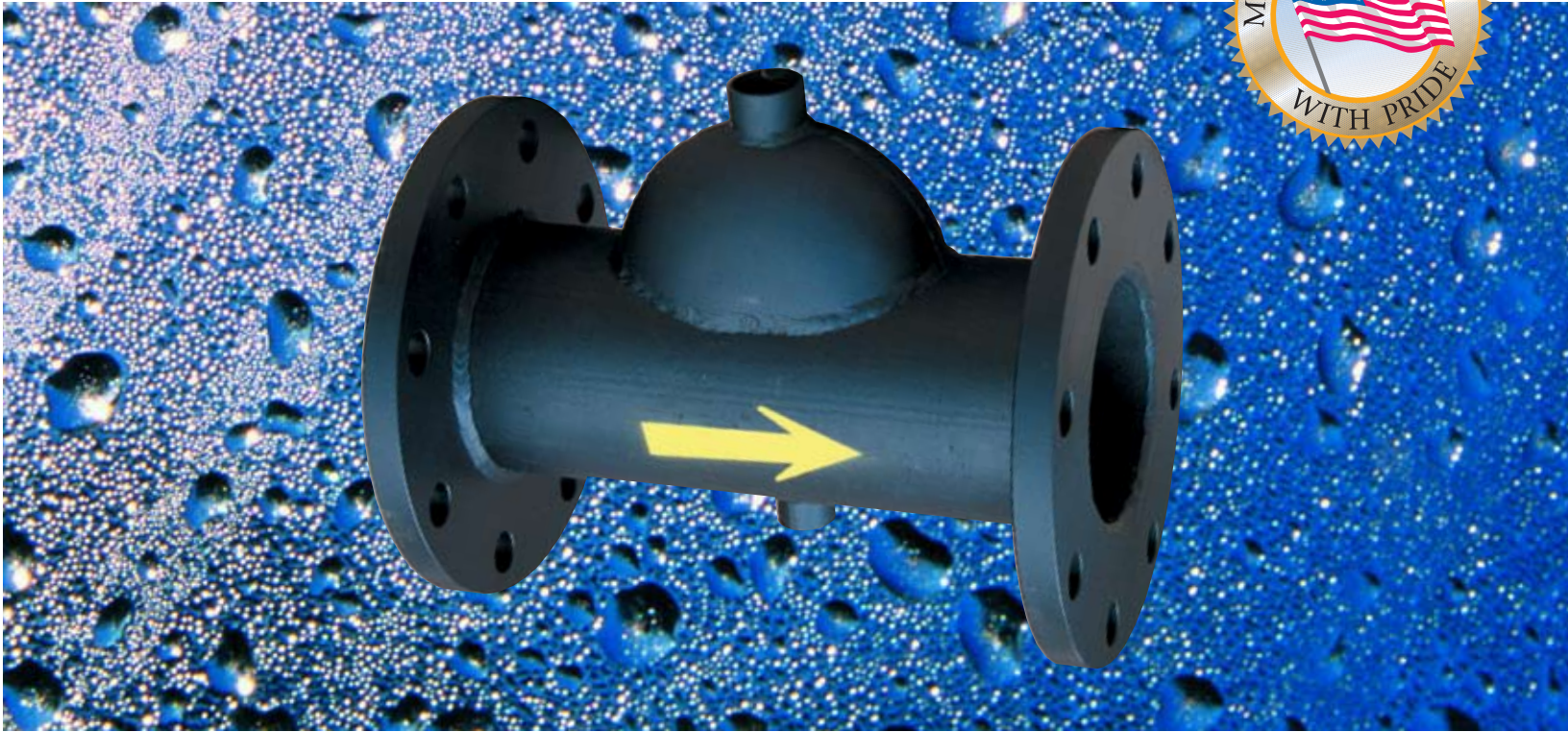

IN-LINE AIR SEPARATOR 3"-24"

fh® **FLEX-HOSE** CO. INC.



The PurgAir™ Advantage – An Air Free System.

PURGAIR inline air separator saves valuable space and the internal diverter design is a cost-effective means for separation of air in a hydronic system. The Purgair are fitted with air vent tapping and drain connection tapping. Purgair's rugged construction makes it suitable for pipe line mounting. Standard pressure ratings of 150 psi. Available with 150 lb. plate steel flanges, butt weld ends and groove ends. We 100% pressure test every PurgAir to assure trouble-free installation and years of quality service.

Benefits

- Air-free water flow means enhanced systems operations and reduced costs
- Internal diverter effectively separates air from heating and cooling systems. The result: better performance and lower operating costs
- Permits quick venting of air at start-up
- Reduces service costs due to air-bound piping
- Extends the life of your system by reducing corrosion and erosion
- Improves heat transfer efficiency in boilers, fan coils, chillers, etc.
- Reduces the overall energy costs of your system
- Optimizes pump performance

Applications

PurgAir Air Separators should be installed at the highest temperature and the lowest pressure points in the system. When this is not possible, the best location is at the point of highest temperature. Ideally, a separator should be located on the outlet side of the boiler, and the suction side of the pump.



Standard Sizes 3" to 24" I.D.

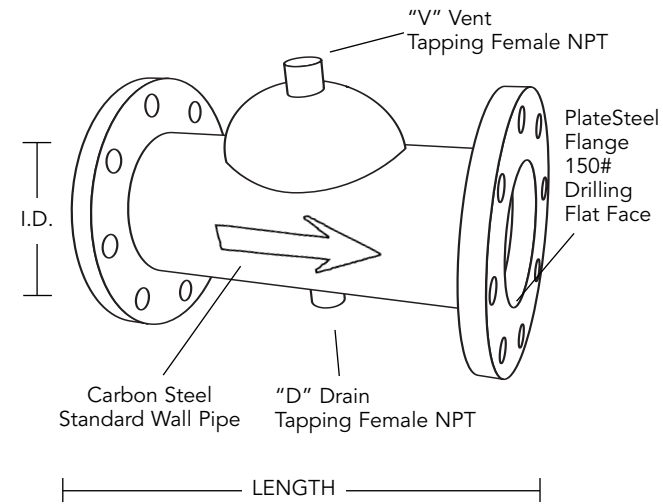

STANDARD SIZES 3" TO 24" • AVAILABLE UP TO 48" DIAMETER • Please consult factory for end fitting configurations

PurgAir Flanged Ends

NOMINAL IN.	MM	LENGTH In.	MM	"C" In.	MM	PRESSURE PSI	kPa	"V" NPT	"D" NPT	WEIGHT LBS	KGS
3	75	12	305	4.50	114	150	1030	.75	.50	26	12
4	100	12	305	5.00	125	150	1030	.75	.50	32	15
5	125	20	510	7.50	190	150	1030	1.25	1.50	56	26
6	150	24	610	8.50	215	150	1030	1.25	1.50	78	36
8	200	32	815	11.25	285	150	1030	1.25	1.50	159	73
10	250	40	1015	14.00	355	150	1030	1.25	1.50	244	111
12	300	48	1220	16.75	425	150	1030	1.25	1.50	359	163
14	350	42	1065	19.38	490	150	1030	1.25	1.50	390	177
16	400	48	1220	20.00	500	150	1030	1.25	1.50	510	232
18	450	54	1370	23.50	595	150	1030	1.25	1.50	600	273
20	500	54	1370	25.00	635	150	1030	1.25	1.50	711	324
24	600	60	1525	27.00	685	150	1030	1.25	1.50	1034	470

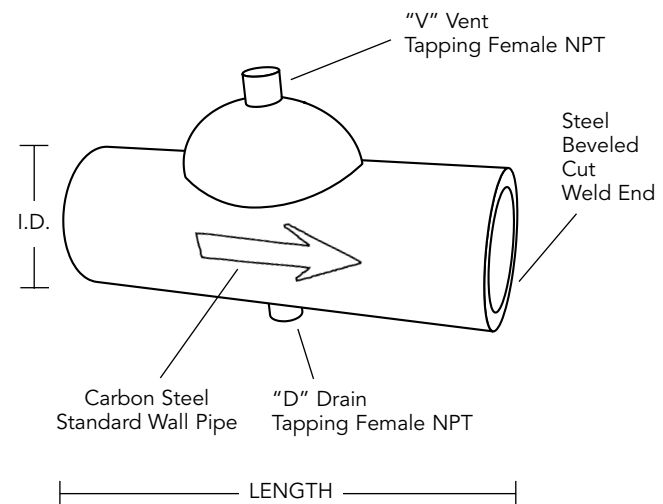

STANDARD SIZES 3" TO 24" • AVAILABLE UP TO 48" DIAMETER • Please consult factory for end fitting configurations

PurgAir Weld Ends

NOMINAL IN.	MM	LENGTH In.	MM	"C" In.	MM	PRESSURE PSI	kPa	"V" NPT	"D" NPT	WEIGHT LBS	KGS
3	75	12	305	4.50	114	150	1030	.75	.50	15	7
4	100	12	305	5.00	125	150	1030	.75	.50	17	8
5	125	20	510	7.50	190	150	1030	1.25	1.50	36	17
6	150	24	610	8.50	215	150	1030	1.25	1.50	55	25
8	200	32	815	11.25	285	150	1030	1.25	1.50	140	64
10	250	40	1015	14.00	355	150	1030	1.25	1.50	188	86
12	300	48	1220	16.75	425	150	1030	1.25	1.50	277	126
14	350	42	1065	19.38	490	150	1030	1.25	1.50	290	132
16	400	48	1220	20.00	500	150	1030	1.25	1.50	370	168
18	450	54	1370	23.50	595	150	1030	1.25	1.50	445	202
20	500	54	1370	25.00	635	150	1030	1.25	1.50	527	240
24	600	60	1525	27.00	685	150	1030	1.25	1.50	770	350

PurgAir Performance Curve

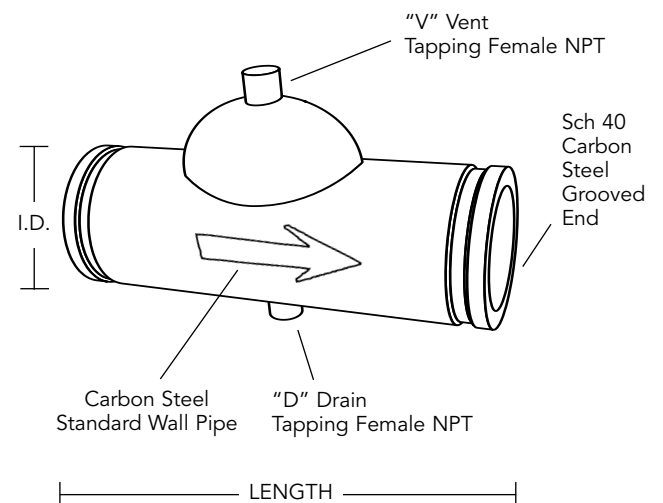
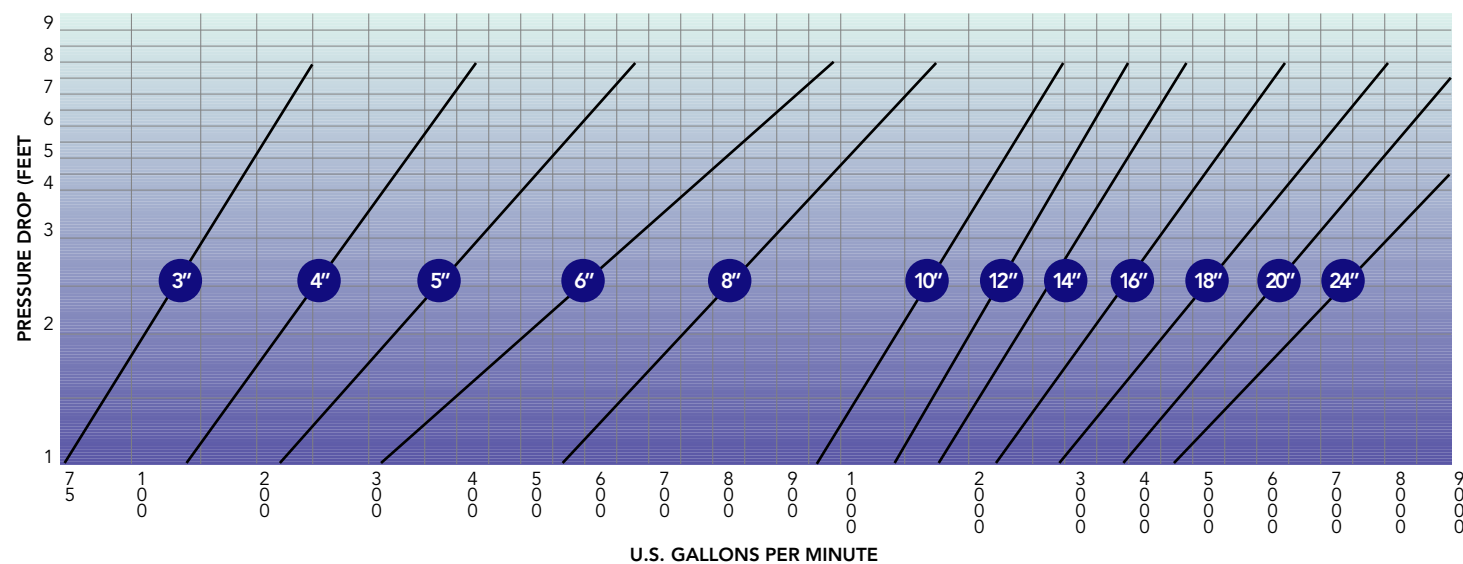

STANDARD SIZES 3" TO 24" • AVAILABLE UP TO 48" DIAMETER • Please consult factory for end fitting configurations

PurgAir Grooved Ends

NOMINAL IN.	MM	LENGTH In.	MM	"C" In.	MM	PRESSURE PSI	kPa	"V" NPT	"D" NPT	WEIGHT LBS	KGS
3	75	12	305	4.50	114	150	1030	.75	.50	15	7
4	100	12	305	5.00	125	150	1030	.75	.50	17	8
5	125	20	510	7.50	190	150	1030	1.25	1.50	36	17
6	150	24	610	8.50	215	150	1030	1.25	1.50	55	25
8	200	32	815	11.25	285	150	1030	1.25	1.50	140	64
10	250	40	1015	14.00	355	150	1030	1.25	1.50	188	86
12	300	48	1220	16.75	425	150	1030	1.25	1.50	277	126
14	350	42	1065	19.38	490	150	1030	1.25	1.50	290	132
16	400	48	1220	20.00	500	150	1030	1.25	1.50	370	168
18	450	54	1370	23.50	595	150	1030	1.25	1.50	445	202
20	500	54	1370	25.00	635	150	1030	1.25	1.50	527	240
24	600	60	1525	27.00	685	150	1030	1.25	1.50	770	350

Visit our website for more information on our broad range of products.



Product Overview

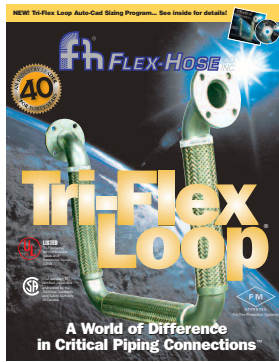

Flexible Pipe Loop

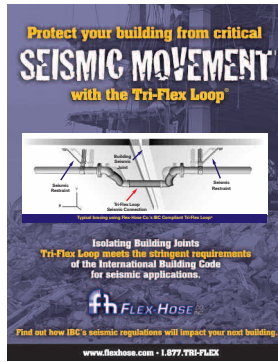

IBC Compliant Seismic Connections

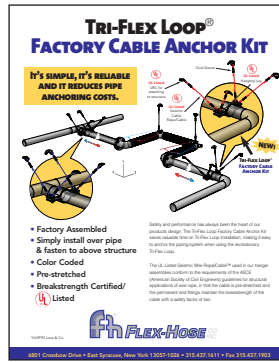

Flexible Pipe Loop Hanger Kit & Accessories



Braided Metal Pump Connectors

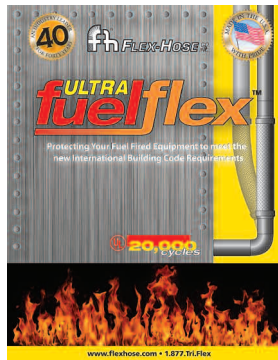

UL Listed Flexible Gas Connection

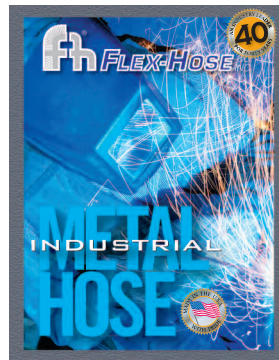

Industrial Metal Hose

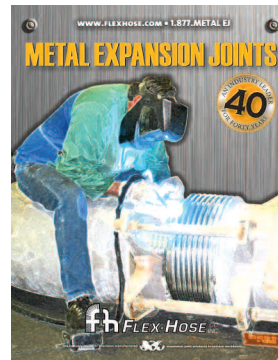

Metal Bellows Expansion Joints

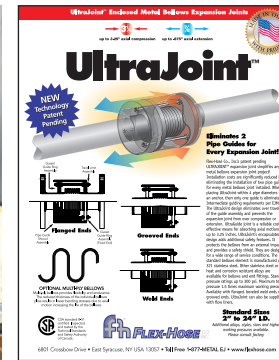

Enclosed Metal Bellows Expansion Joints

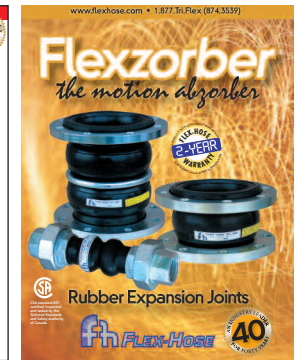

Rubber Expansion Joints

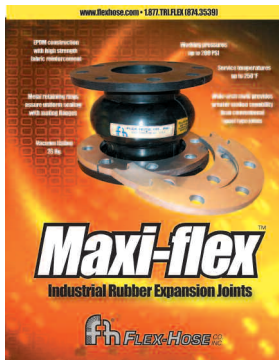

Industrial Rubber Expansion Joints



Expansion Joint Control Assemblies

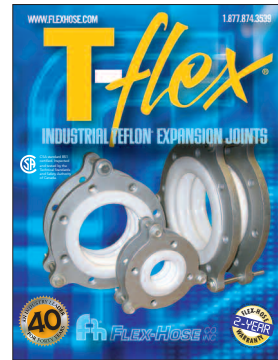

Teflon® Expansion Joints



Air Separators

A World of Difference in Critical Piping Connections since 1968.



Corporate Headquarters
6801 Crossbow Drive • East Syracuse, NY 13057
315.437.1611 • Fax 315.437.1903

Expanded Design and Manufacturing Operation
6809 Crossbow Drive • East Syracuse, NY 13057
315.701.0001 • Fax 315.701.0032

Toll Free 1-877-Tri-Flex (874-3539)