

AssureFlex® Tri-Flex Loop® Expansion Loops & Seismic Connectors for Fire Protection

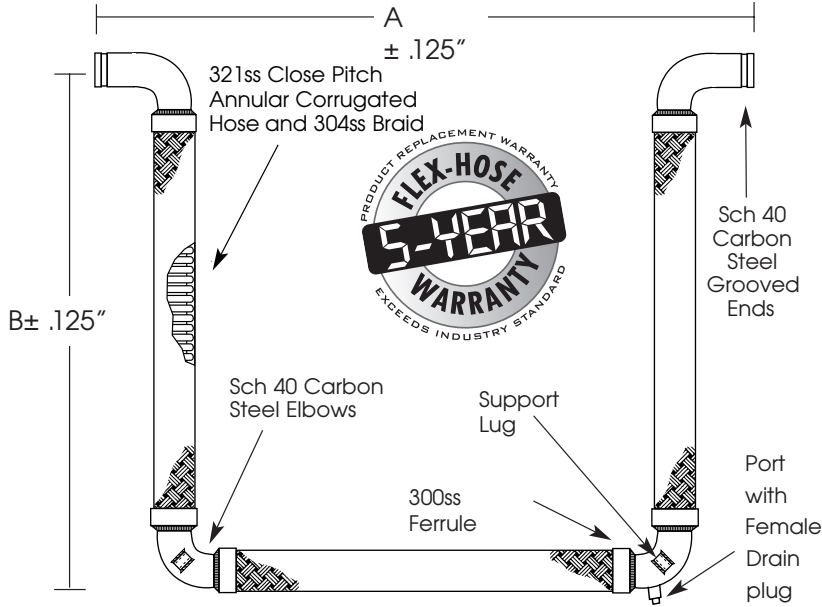

UL US
LISTED
EX28995
(Flexible Joint Fitting)

CSA standard B-51 certified.
Inspected and tested by the
Technical Standards and
Safety Authority of Canada.



Qty	I.D. (in.)	Dimensions		Pressure (PSI) @70° F	Movement Capability					Drain Port (in.)	Wt. (lb.)	Notes
		"A" (in.)	"B" (in.)		Compression (in.)	Extension (in.)	Parallel (in.)	Rotate "X" Axis (Deg.)	Non-parallel "Y" Axis (in.)			
	4.00	48.75	33.00	300	2.0	2.0	2.0	5°	1.0	¾"	71	
	5.00	64.50	44.50	300	2.0	2.0	2.0	5°	1.0	¾"	142	
	6.00	74.00	50.75	300	2.0	2.0	2.0	3°	1.0	¾"	189	

Working pressures shown for the hose and braid are based on an operating temperature of 70°F (21°C) with a 4:1 safety factor. Provided with two braids.

Movement Capability

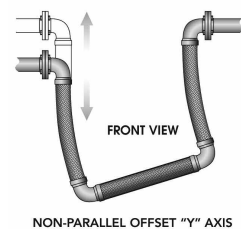
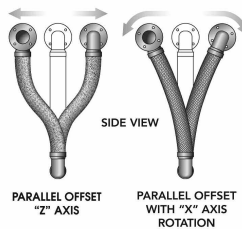
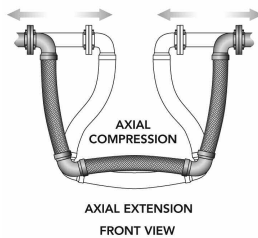

PROJECT	
CUSTOMER	
ENGINEER	
REPRESENTATIVE	
DRAWING #	



4560 Buckley Road • Liverpool, NY USA 13088-2509
315/437-1611 • Fax 315/437-1903
www.flexhose.com • 1.877.TRI FLEX