

AssureFlex® Two-Leg U Style Seismic and Expansion Loop for Fire Protection

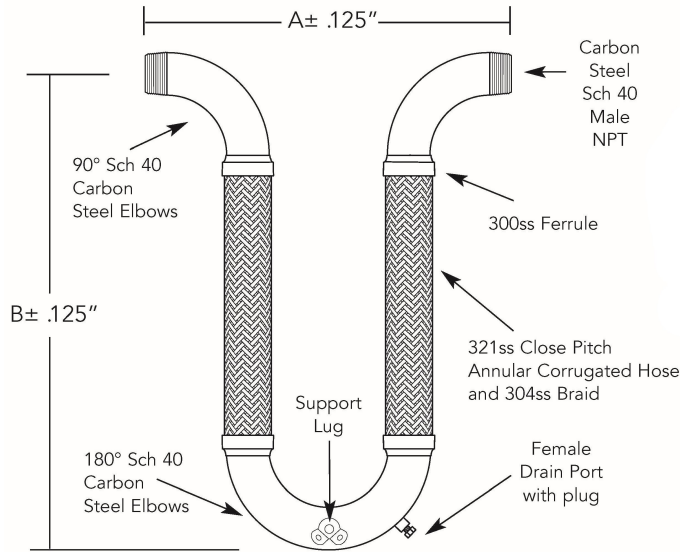

CSA standard B-51 certified.
Inspected and tested by the
Technical Standards and
Safety Authority of Canada.

QTY.	I.D. (in.)	Length (in.)		Pressure (PSI) @70° F	Drain Port (in.)	Weight (lb.)	Comments
		A (in.)	B (in.)				
	1.00	15.00	20.00	300	½	6.0	
	1.25	15.75	21.00	300	½	7.5	
	1.50	17.50	23.00	300	½	9.0	
	2.00	20.00	25.00	300	½	15.0	
	2.50	21.50	28.00	300	¾	25.0	
	3.00	24.00	30.00	300	¾	34.0	
	4.00	30.00	35.00	175	¾	58.0	

MOVEMENT CAPABILITY: +/- 4"

PROJECT	
CUSTOMER	
ENGINEER	
REPRESENTATIVE	
DRAWING #	



4560 Buckley Road
Liverpool, NY USA 13088-2509
315/437-1611 • Fax 315/437-1903
www.flexhose.com • 1.877.TRI FLEX