

# Pumpsaver® Braided Pump Connectors

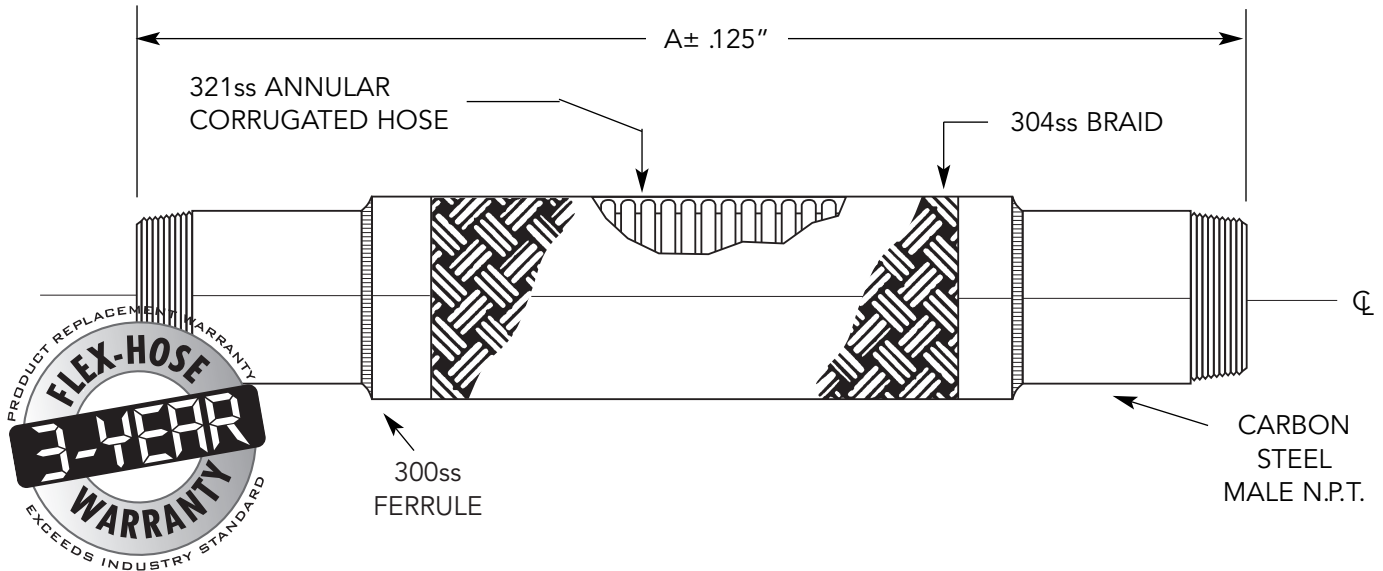

FOR TEMP ABOVE 70°F	
TEMP °F	FACTOR S.S.
70	1.00
200	.94
300	.88
400	.83
500	.78
600	.74

\*For safe working pressure above 70°F, multiply pressure shown at 70°F times correction factor of required temp.

Qty	I.D. (In.)	A (In.)	Pressure (PSI) 70°F	Parallel Offset (In.)		Weight (lb)	NOTES
				Permanent	Intermittent		
	.50	8.50	1100	1	¼	.56	
	.75	10.00	800	1 ⅝	⅜	.87	
	1.00	10.00	750	1	¼	1.10	
	1.25	11.00	725	1 ½	½	1.43	
	1.50	12.00	565	1 ¾	⅝	1.80	
	2.00	14.00	500	1 ⅜	½	2.92	
	2.50	16.00	400	2	¾	4.64	
	3.00	18.00	285	2	1	6.84	
	4.00	20.00	250	2 ¼	1 ½	9.20	

\*Working pressures shown for the hose and braid are based on an operating temperature of 70°F (21°C) with a 4:1 safety factor.

END FITTING OPTIONS: SCH'D 40 IPS  SCH'D 80 IPS



CSA standard B-51 certified. Inspected and tested by the Technical Standards and Safety Authority of Canada.



This product is listed by IAPMO R&T under file #N-7208 for NSF/ANSI 61 and file 7207 for California Lead Plumbing Law and NSF/ANSI-372. Our listed products can be viewed on IAPMO R&T's Web listing at <http://pld.iapmo.org>

PROJECT	
CUSTOMER	
ENGINEER	
REPRESENTATIVE	
DRAWING #	



6801 Crossbow Drive  
 East Syracuse, NY USA 13057-1026  
 315/437-1611 • Fax 315/437-1903  
[www.flexhose.com](http://www.flexhose.com) • 1.877.TRI FLEX

