

Pumpsaver® Braided Pump Connectors

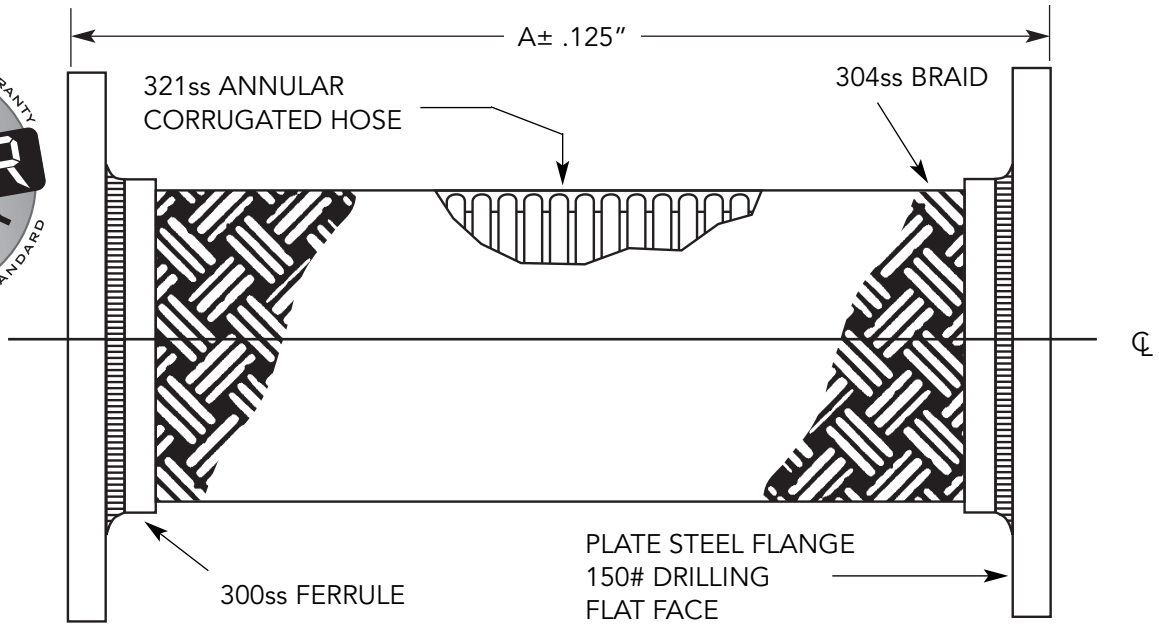

FOR TEMP ABOVE 70°F	
TEMP °F	FACTOR S.S.
70	1.00
200	.94
300	.88
400	.83
500	.78
600	.74

*For safe working pressure above 70°F, multiply pressure shown at 70°F times correction factor of required temp.

QTY	I.D. (In.)	A (In.)	*Pressure (PSI) @ 70°F	NOTES
	2.00		500	
	2.50		400	
	3.00		285	
	4.00		250	
	5.00		200	
	6.00		220	
	8.00		215	
	10.00		200	
	12.00		160	
	14.00		150	

*Working pressures shown for the hose and braid are based on an operating temperature of 70°F (21°C) with a 4:1 safety factor.



CSA standard B-51 certified. Inspected and tested by the Technical Standards and Safety Authority of Canada.



This product is listed by IAPMO R&T under file #N-7208 for NSF/ANSI 61 and file 7207 for California Lead Plumbing Law and NSF/ANSI-372. Our listed products can be viewed on IAPMO R&T's Web listing at <http://pld.iapmo.org>



PROJECT	
CUSTOMER	
ENGINEER	
REPRESENTATIVE	
DRAWING #	



6801 Crossbow Drive
 East Syracuse, NY USA 13057-1026
 315/437-1611 • Fax 315/437-1903
www.flexhose.com • 1.877.TRI FLEX