

Pumpsaver® Braided Pump Connectors

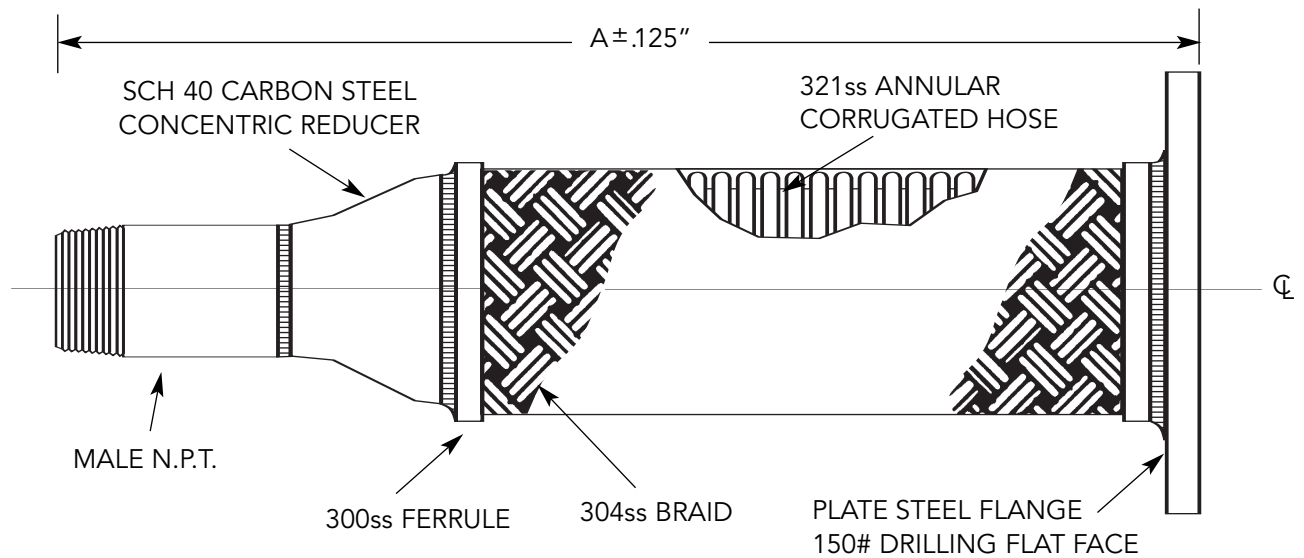

FOR TEMP ABOVE 70°F	
TEMP °F	FACTOR S.S.
70	1.00
200	.94
300	.88
400	.83
500	.78
600	.74

Small Male	I.D. (In.)		Length (In.)	Pressure (PSI) 70°F	Parallel Offset (In.)		Weight (lb)	Notes
	Large Flange & Hose				Permanent	Intermittent		
1.00	1.25		13.00	550	1 5/8	3/4	4.20	
1.00	1.50		13.00	450	1 1/2	1/2	4.90	
1.00	2.00		14.00	450	1 1/8	3/8	7.30	
1.25	1.50		13.00	450	1 1/2	1/2	4.90	
1.25	2.00		14.00	450	1 1/8	3/8	7.30	
1.50	2.00		14.00	450	1 1/8	3/8	7.30	
1.50	2.50		14.00	300	1	3/8	10.50	
2.00	2.50		15.00	300	1	3/8	10.50	
2.00	3.00		15.00	275	5/8	1/4	14.00	

*Working pressures shown for the hose and braid are based on an operating temperature of 70°F (21°C) with a 4:1 safety factor.

*For safe working pressure above 70°F, multiply pressure shown at 70°F times correction factor of required temp.



CSA standard B-51 certified. Inspected and tested by the Technical Standards and Safety Authority of Canada.



PROJECT	
CUSTOMER	
ENGINEER	
REPRESENTATIVE	
DRAWING #	



6801 Crossbow Drive
 East Syracuse, NY USA 13057-1026
 315/437-1611 • Fax 315/437-1903
 www.flexhose.com • 1.877.TRI FLEX

WS20160113

STAINLESS STEEL PUMP CONNECTORS

SF/CI-Mx15P 1"-2 1/2" I.D.