

PurgAir™



IN-LINE AIR SEPARATOR 3" - 18"

FLEX-HOSE CO., INC.  [®]

The PurgAir™ Advantage – An Air Free System.

PURGAIR inline air separator saves valuable space and the internal diverter design is a cost-effective means for separation of air in a hydronic system. The Purgair are fitted with air vent tapping and drain connection tapping. Purgair's rugged construction makes it suitable for pipe line mounting. Standard pressure ratings of 150 psi. Available with 150 lb. plate steel flanges, butt weld ends and groove ends. We 100% pressure test every PurgAir to assure trouble-free installation and years of quality service.

Benefits

- Air-free water flow means enhanced systems operations and reduced costs
- Internal diverter effectively separates air from heating and cooling systems. The result: better performance and lower operating costs
- Permits quick venting of air at start-up
- Reduces service costs due to air-bound piping
- Extends the life of your system by reducing corrosion and erosion
- Improves heat transfer efficiency in boilers, fan coils, chillers, etc.
- Reduces the overall energy costs of your system
- Optimizes pump performance

Applications

PurgAir Air Separators should be installed at the highest temperature and the lowest pressure points in the system. When this is not possible, the best location is at the point of highest temperature. Ideally, a separator should be located on the outlet side of the boiler, and the suction side of the pump.

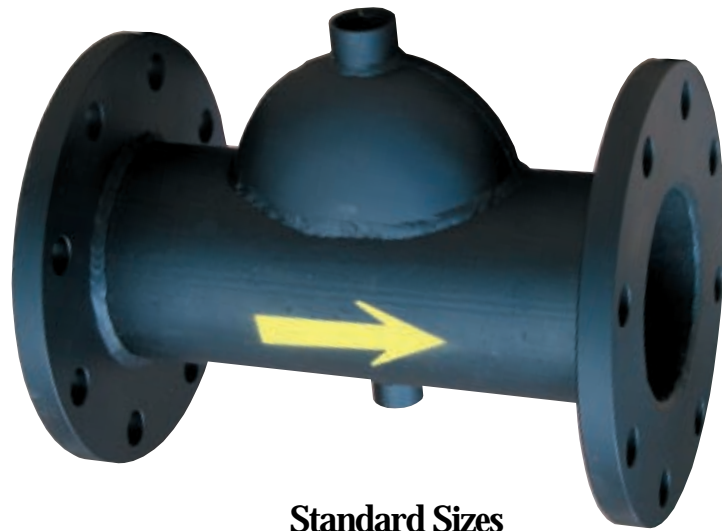

Standard Sizes
3" to 18" I.D.

PurgAir Performance Curve

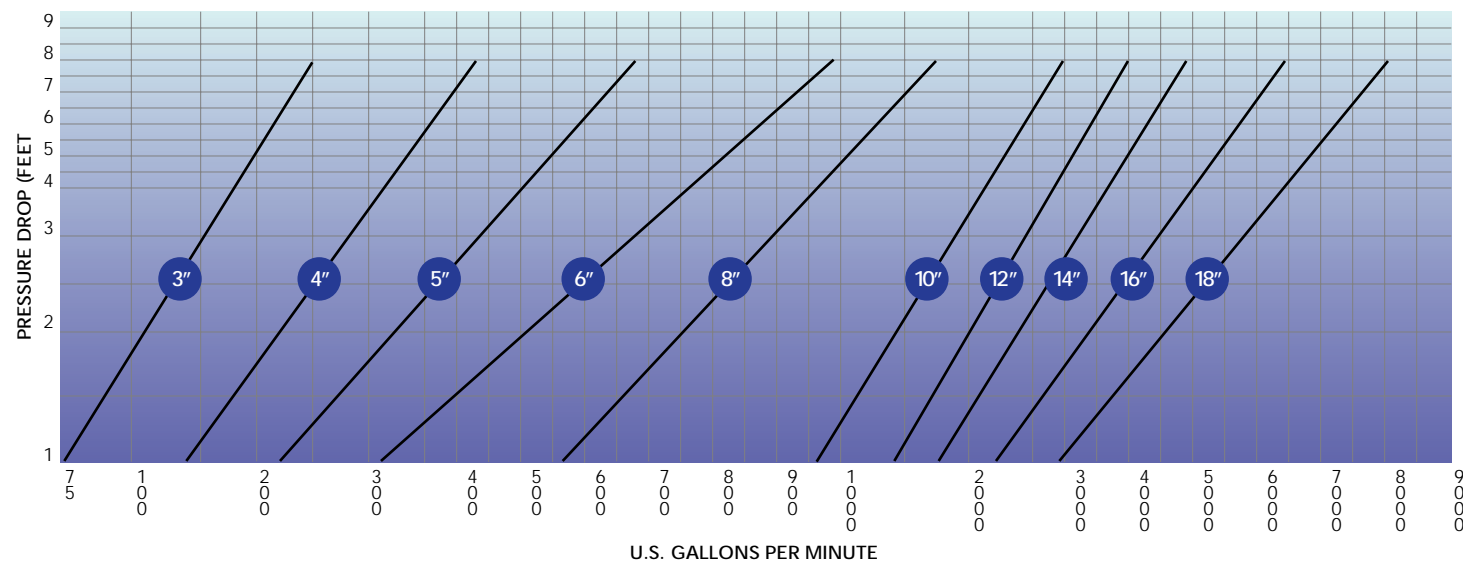

PurgAir Flanged Ends

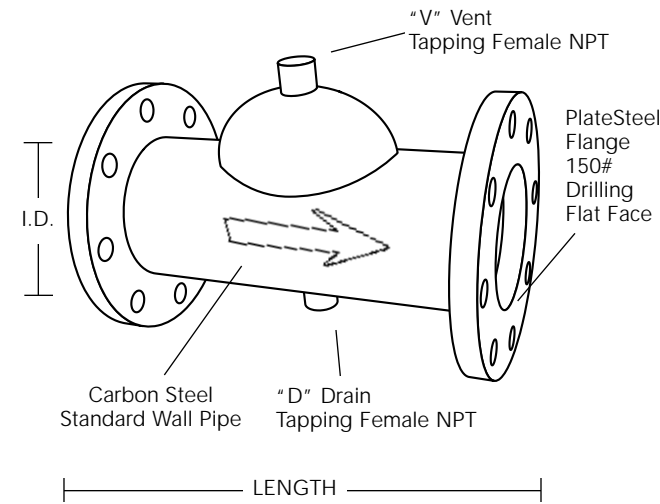

NOMINAL IN.	MM	LENGTH		"C"		PRESSURE		"V"	"D"	WEIGHT	
		In.	MM	In.	MM	PSI	kPa	NPT	NPT	LBS	KGS
3	75	12	305	4.50	114	150	1030	.75	.50	26	12
4	100	12	305	5.00	125	150	1030	.75	.50	32	15
5	125	20	510	7.50	190	150	1030	1.25	1.50	56	26
6	150	24	610	8.50	215	150	1030	1.25	1.50	78	36
8	200	32	815	11.25	285	150	1030	1.25	1.50	159	73
10	250	40	1015	14.00	355	150	1030	1.25	1.50	244	111
12	300	48	1220	16.75	425	150	1030	1.25	1.50	359	163
14	350	42	1065	19.38	490	150	1030	1.25	1.50	390	177
16	400	48	1220	20.00	500	150	1030	1.25	1.50	510	232
18	450	54	1370	23.50	595	150	1030	1.25	1.50	600	273

PurgAir Weld Ends

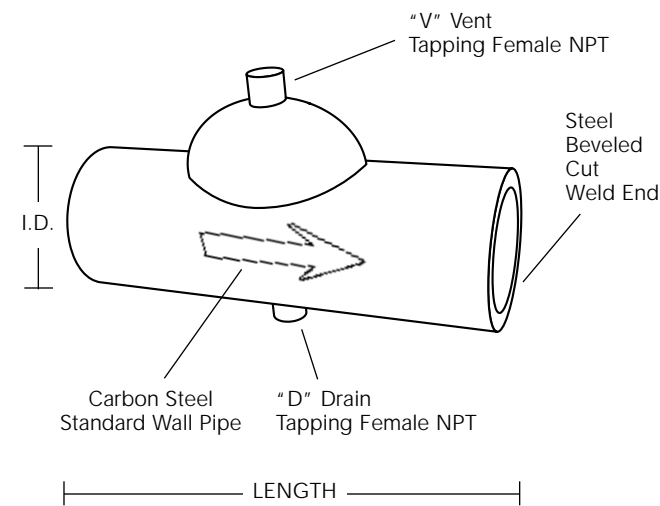

NOMINAL IN.	MM	LENGTH		"C"		PRESSURE		"V"	"D"	WEIGHT	
		In.	MM	In.	MM	PSI	kPa	NPT	NPT	LBS	KGS
3	75	12	305	4.50	114	150	1030	.75	.50	15	7
4	100	12	305	5.00	125	150	1030	.75	.50	17	8
5	125	20	510	7.50	190	150	1030	1.25	1.50	36	17
6	150	24	610	8.50	215	150	1030	1.25	1.50	55	25
8	200	32	815	11.25	285	150	1030	1.25	1.50	140	64
10	250	40	1015	14.00	355	150	1030	1.25	1.50	188	86
12	300	48	1220	16.75	425	150	1030	1.25	1.50	277	126
14	350	42	1065	19.38	490	150	1030	1.25	1.50	290	132
16	400	48	1220	20.00	500	150	1030	1.25	1.50	370	168
18	450	54	1370	23.50	595	150	1030	1.25	1.50	445	202

PurgAir Grooved Ends

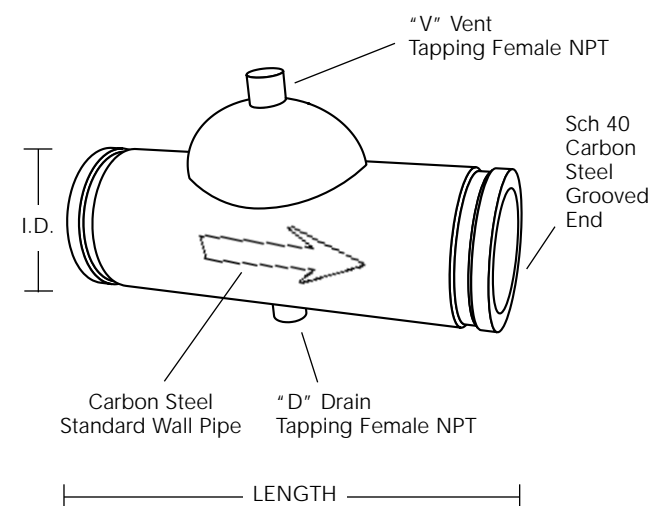

NOMINAL IN.	MM	LENGTH		"C"		PRESSURE		"V"	"D"	WEIGHT	
		In.	MM	In.	MM	PSI	kPa	NPT	NPT	LBS	KGS
3	75	12	305	4.50	114	150	1030	.75	.50	15	7
4	100	12	305	5.00	125	150	1030	.75	.50	17	8
5	125	20	510	7.50	190	150	1030	1.25	1.50	36	17
6	150	24	610	8.50	215	150	1030	1.25	1.50	55	25
8	200	32	815	11.25	285	150	1030	1.25	1.50	140	64
10	250	40	1015	14.00	355	150	1030	1.25	1.50	188	86
12	300	48	1220	16.75	425	150	1030	1.25	1.50	277	126
14	350	42	1065	19.38	490	150	1030	1.25	1.50	290	132
16	400	48	1220	20.00	500	150	1030	1.25	1.50	370	168
18	450	54	1370	23.50	595	150	1030	1.25	1.50	445	202

Make the Right Connection with our Representative:

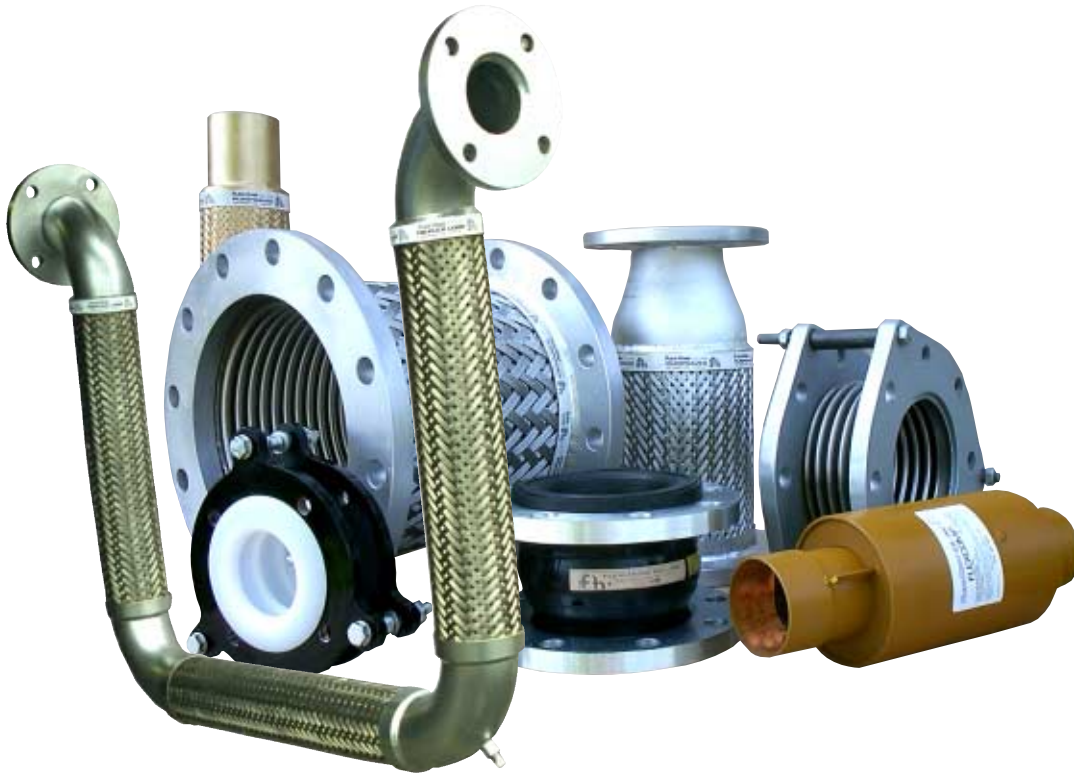

FLEX-HOSE CO., INC. 

6801 Crossbow Drive • East Syracuse, New York 13057-1026

Telephone 315.437.1611 • Fax 315.437.1903

Toll Free 1-877-Tri-Flex (874-3539)

email: flexhose@flexhose.com

Visit us on the web — www.flexhose.com